

REPLACEMENT PARTS

Not all components of the jack are replacement items, but are illustrated as a convenient reference of location and position in the assembly sequence. When ordering parts, give Model number, part number and description below. Call or write for current pricing: Mac Tools Inc. 505 N. Cleveland Ave. Suite 200, Westerville, OH 43082. Tel: 1-800-MAC-TOOL (622-8665)

Replacement Parts Illustration for Model JSA22D & JSA22LOWPRO:

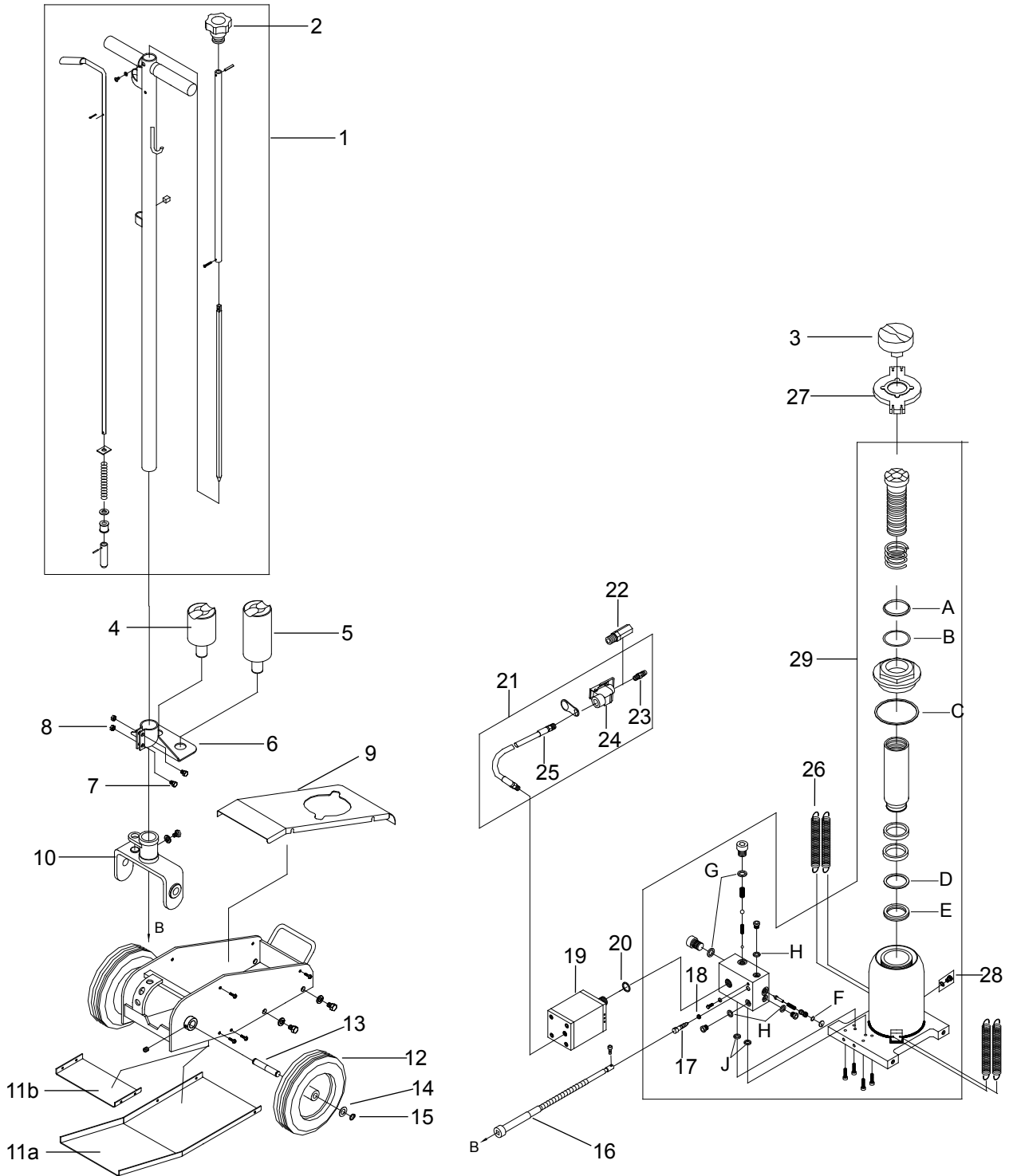

Figure 2 - Model JSA22D & JSA22LOWPRO Replacement Parts Illustration

Replacement Parts List for Model JSA22D & JSA22LOWPRO

Ref.	Part# for JSA22D	Part# for JSA22LOWPRO	Description	Qty.
1	A09-4-2200-106		Handle Assembly	1
2	421-6-2202-209		Knob, Release Valve	1
3	A07-5-1108-105		Saddle	1
4	A07-6-1109-103		Adapter, 2-1/2"	1
5	N/A	A09-5-1103-109	Adapter, 5"	1
6	A09-6-1104-107		Adapter Holder	1
7	653-1-0080-025		Hex Bolt	2
8	661-2-0080-023		Nut	2
9	A09-6-3221-101		Cover Plate, Upper	1
10	A07-6-1301-105		Handle Socket	1
11a	A09-6-3124-104	N/A	Base Plate	1
11b	N/A	A07-6-3214-201		
12	A07-4-3400-509		Wheel	2
13	A07-6-3230-300		Axle, Wheel	2
14	611-3-0130-101		Washer	2
15	667-5-0127-005		C-clip	2
16	A07-3-3300-307		Release Valve Cable	1
17	A09-6-1701-105		Release Valve	1
18	554-7-0062-007		Seal	1
19	A27010-0001		Air Motor	1
20	515-3-0140-103		Copper Gasket	1
21	A20060-0005		Air Hose Assembly	1
22	A07-4-2900-100		Filter	1
23	A20060-0016		Quick Coupler, Male 1/4NPT	1
24	A20060-0007		Lift Control Valve	1
25	A20060-0006		Air Hose	1
26	523-2-0196-016	523-2-0198-203	Return Spring	4
27	A07-5-1802-101		Spring Plate	1
28	324-4-1900-208		Filler Screw	1
29	A09-1-1011-217	A09-1-1011-210	Hydraulic Unit	1
*	A09-3-9901-206		Seal Kit	-
-	JSA22D-L0	JSA22LOWPRO-L0	Label	-
-	JSA22D-M0		Manual	-

(*) Seal Kit Contents:

Item	Description	Qty.
18	Seal	1
20	Copper Gasket	1
28	Filler Screw	1
A	Dust Seal	1
B	O-ring	1
C	Gasket	1

Item	Description	Qty.
D	Back-up Ring	1
E	U-cup	1
F	O-ring	1
G	Special Washer	2
H	Special Washer	3
J	O-ring	2